

Product Selection Guide

Item	Measuring Method	Condition	Unit	starex						INFINO							
				ABS			FR ABS		FR ABS/PC	PC			FR PC/ABS				
				SD-0150	HG-0760 GP	BC-0130 X	VH-0815	VE-0860	New	UF-1017S	UF-1063	UF-1043	NH-1015V	NH-1037	NH-1039	NH-1041	

Physical Properties

250°C, 10kg 260°C, 5kg

Specific Gravity	ASTM D792	-	g/cm ³	1.05	1.04	1.05	1.15	1.19	1.19	1.20	1.19	1.19	1.17	1.19	1.18	1.18
Melt Flow Index	ASTM D1238	220°C, 10kg	g/10min	20	40	26	38	18	20	19	19	23	30	19	12	48
		200°C, 5kg		2.0	4	2.6	-	1.8	-	-	-	-	-	-	-	-
Mold Shrinkage	ASTM D955	220°C, 10kg		-	-	-	-	-	-	19	19	23	30	-	12	-
		260°C, 2.16kg	g/10min	-	-	-	-	-	-	-	-	15	-	20	-	-
		200°C, 5kg		2.0	4	2.6	4.2	1.8	-	-	-	-	-	-	-	-
		Flow at 3.2mm(MD)	%	0.3-0.6	0.3-0.6	0.2-0.5	0.3-0.4	-	-	0.3-0.6	0.4-0.7	0.3-0.6	0.5-0.7	0.4-0.7	0.4-0.7	0.4-0.7

Mechanical Properties

Tensile Strength	ASTM D638	50mm/min	kgf/cm ²	-	-	-	-	-	-	620	620	550	650	670	650	620	
		5mm/min	MPa	420	400	490	400	430	450	-	-	-	-	-	-	-	-
		ISO 527	50mm/min	MPa	51	40	55	45	40	-	61	62	54	61	61	61	-
Flexural Strength	ASTM D790	2.8mm/min	kgf/cm ²	630	600	720	600	650	700	910	930	800	890	1,000	900	900	
		ISO 178	2mm/min	MPa	76	60	86	71	60	-	90	93	80	89	92	85	-
Flexural Modulus	ASTM D790	2.8mm/min	kgf/cm ²	21,000	20,000	24,000	22,000	24,000	25,000	23,500	24,000	22,000	24,000	27,000	24,500	25,000	
		ISO 178	2mm/min	MPa	2,500	2,000	2,700	2,400	2,000	-	2,350	2,400	2,200	2,550	2,500	2,400	-
Izod Impact Strength	ASTM D256	1/4" at 23°C	kgf-cm/cm	20	23	13	25	10	-	-	-	-	-	19	-	-	
		1/8" at 23°C	kgf-cm/cm	20	24	15	-	-	40	65	70	70	55	60	65	50	-
		ISO 180 1A	at 23°C, 4mm	kJ/m ²	17	23	13	19	10	-	64	60	55	14	32	50	-
Charpy Impact Strength (V-notched)	ISO 179 1eA	at 23°C, 4mm	kJ/m ²	17	20	16	22	-	-	67	60	60	17	36	50	-	

Thermal Properties

VICAT Softening Temperature	ISO R 306	B/50	°C	98	96	99	86	95	-	109	107	108	100	110	110	105	
Heat Deflection Temperature	ASTM D648	18.56kgf/cm ² , 6.4mm	°C	84	82	86	77	-	-	-	95	-	86	100	-	93	
		ISO 75-2	1.8MPa, 4mm	°C	79	76	80	71	83	82	93	90	90	82	93	98	-
RTI	Elec	UL746B	1.5 mm	°C	-	-	-	-	-	-	80	80	80	90	60	60	60
			1.5 mm	°C	-	-	-	-	-	-	80	80	80	85	60	60	60
			1.5 mm	°C	-	-	-	-	-	-	-	80	80	80	90	60	60

Flame Retardant Properties

Flammability	UL 94	-	mm	HB	HB	HB	1.5 V-1 2.0 V-0 2.0 5VB	1.5 V-0	2.0 V-0	0.4 V-2 0.7-3.0 V-0	0.6-3.0 V-0	0.75-3.0 V-0	1.5 V-0 2.0 5VB	1.5 V-0 2.5 5VB	1.5 V-0 2.5 5VB	1.5 V-0
--------------	-------	---	----	----	----	----	-------------------------------	---------	---------	------------------------	-------------	--------------	--------------------	--------------------	--------------------	---------

* The above values are only the representatives of natural color, not for guarantee.

Energy Storage

Material Solution for Battery



The Optimal Material Proposals for Lithium-ion Battery

Market Trends & Requirements

“Signs of change in the IT/automotive battery market” tailored for the consumer's lifestyle

- High Performance** The increasing portable use of small IT devices calls for **high performance and large capacity battery**.
- Diversification** **Demand for Lithium-ion batteries has soared** due to the introduction of various new products such as wearable appliances, drone and E-mobility.
- Efficiency** As new renewable energy and smart grid system expand, **energy storage and efficiency have become crucial**.



Fire Safety

Excellent Flame Retardant Material (UL Certification) against Fire Accidents



Durable Housing

Require safety from Impact Strength & Good Chemical Resistance



Long-lasting Performance

High Weatherability & Long-term Heat Stability operating at High Temp.

Product Portfolio

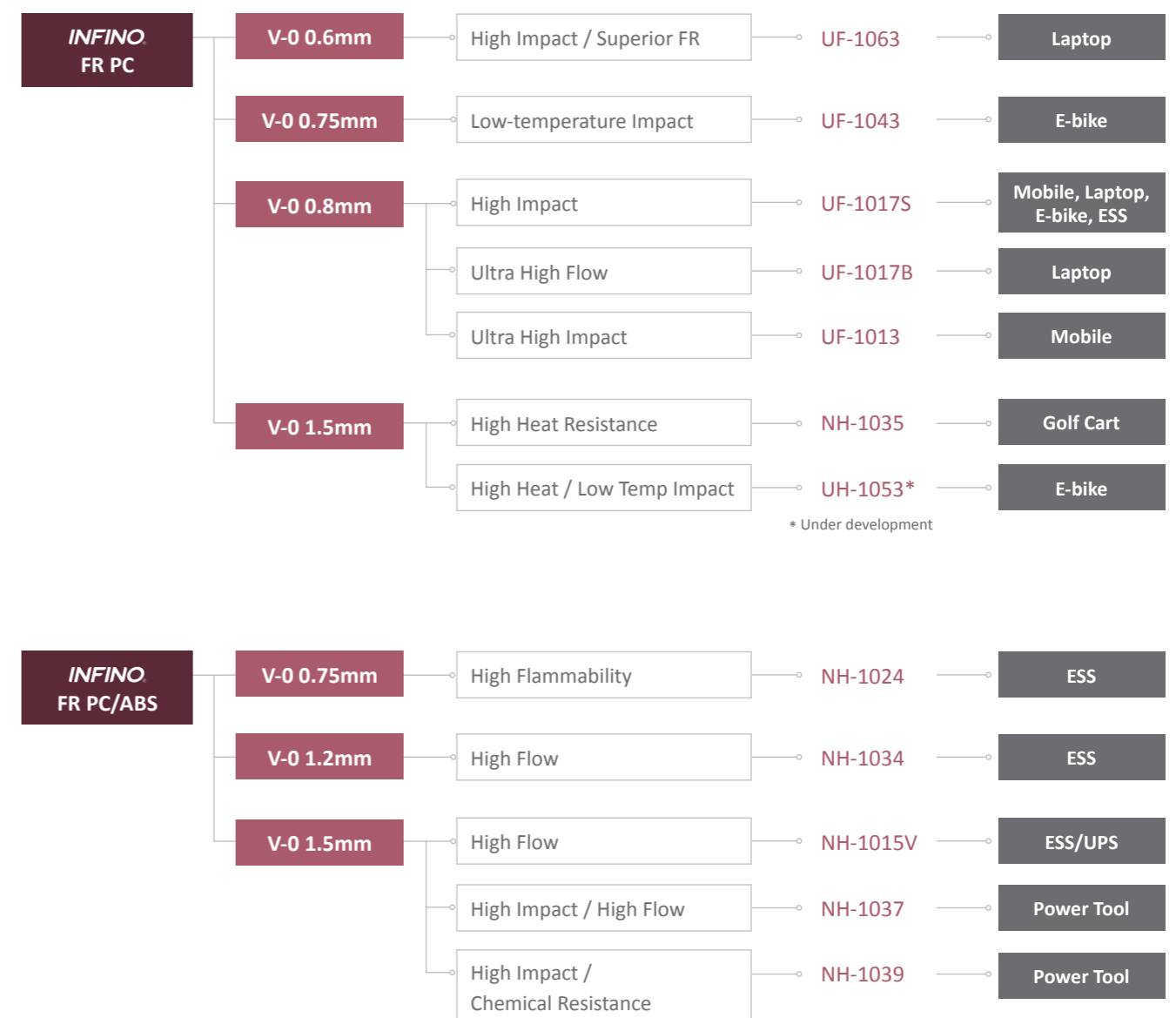

The Optimal Material Proposals for Lithium-ion Battery

Explore Application & Materials

- **Diverse properties needed by applications**
: Surface quality, High impact at low temp., Chemical resistance, Weatherability
- Demand for practical impact and ultra thin-wall flame retardancy following the wider adoption of thin-wall design

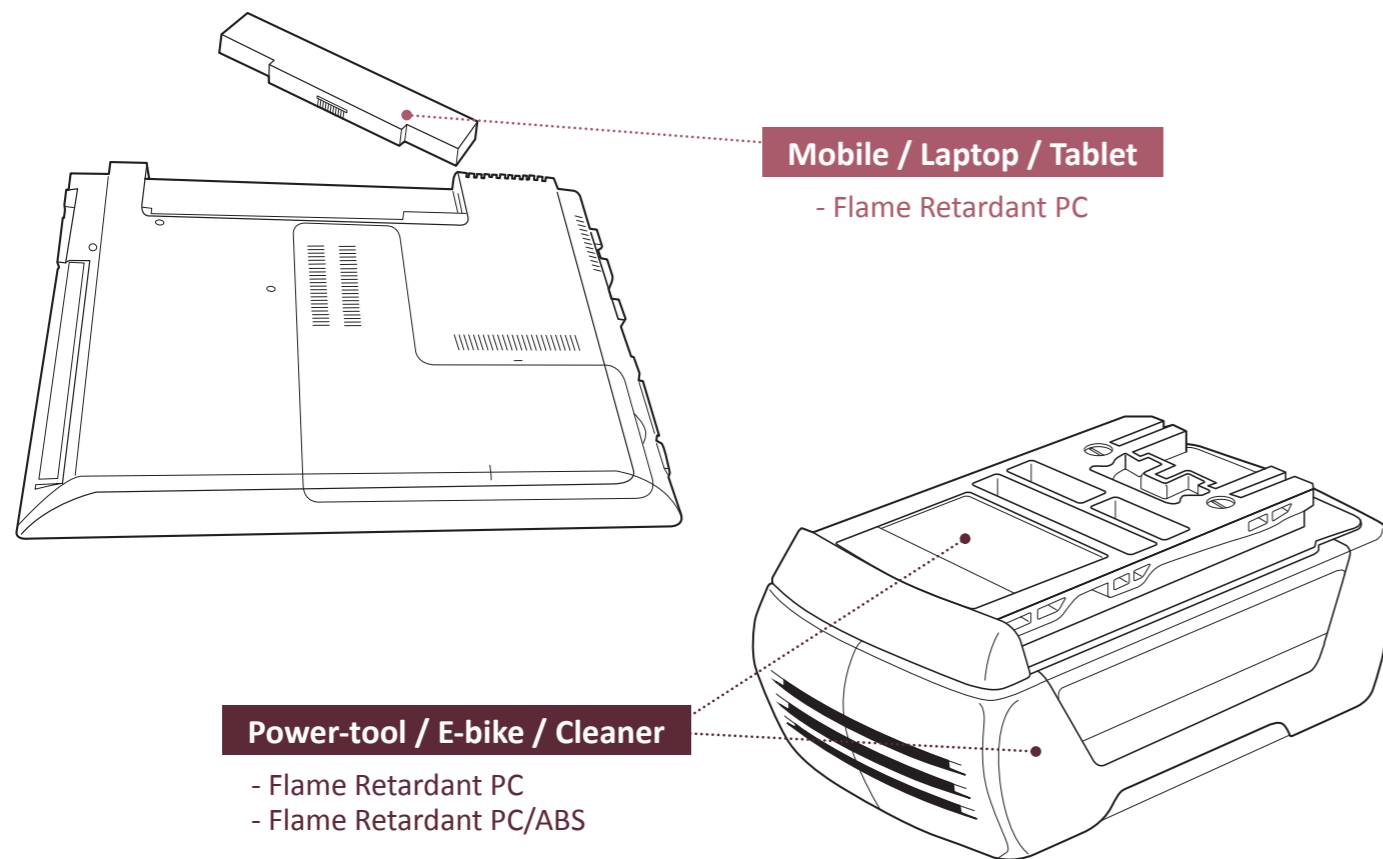

Materials Solutions

>> INFINO FR PC UF-1017S

• **Applications** Mobile, Laptop, E-bike, Cleaner, etc.

• **Key Values**



Flowability



Impact Strength



Thin-Wall

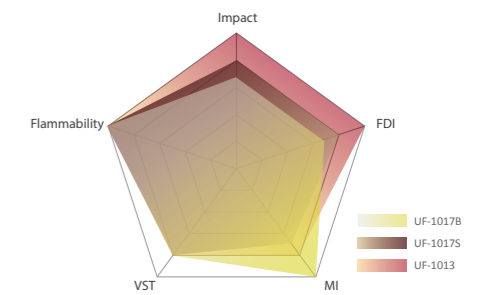

>> INFINO FR PC UF-1063

• **Applications** Laptop

• **Key Values**



Chemical Resistance



Impact Strength



Thin-Wall

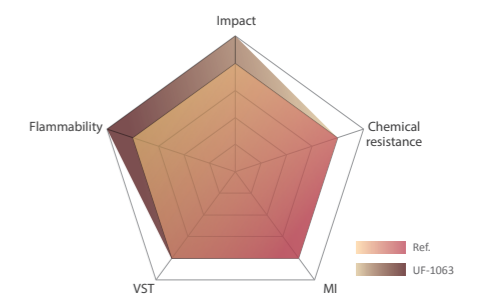

>> INFINO FR PC UF-1043

• **Applications** E-bike

• **Key Values**



UV Resistance



Chemical Resistance



Impact Strength



Thin-Wall

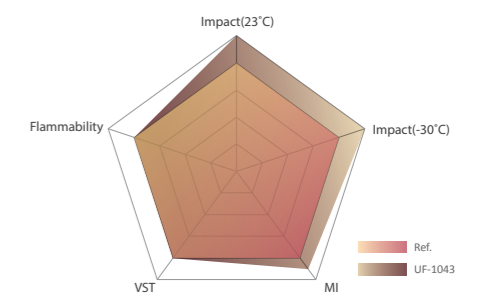

>> INFINO FR PC/ABS NH-1039

• **Applications** Power tool

• **Key Values**



Chemical Resistance



Impact Strength



Heat Resistance

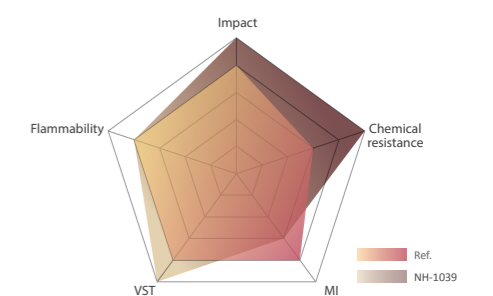

The Optimal Material Proposals for Lead-acid Battery

Product Portfolio

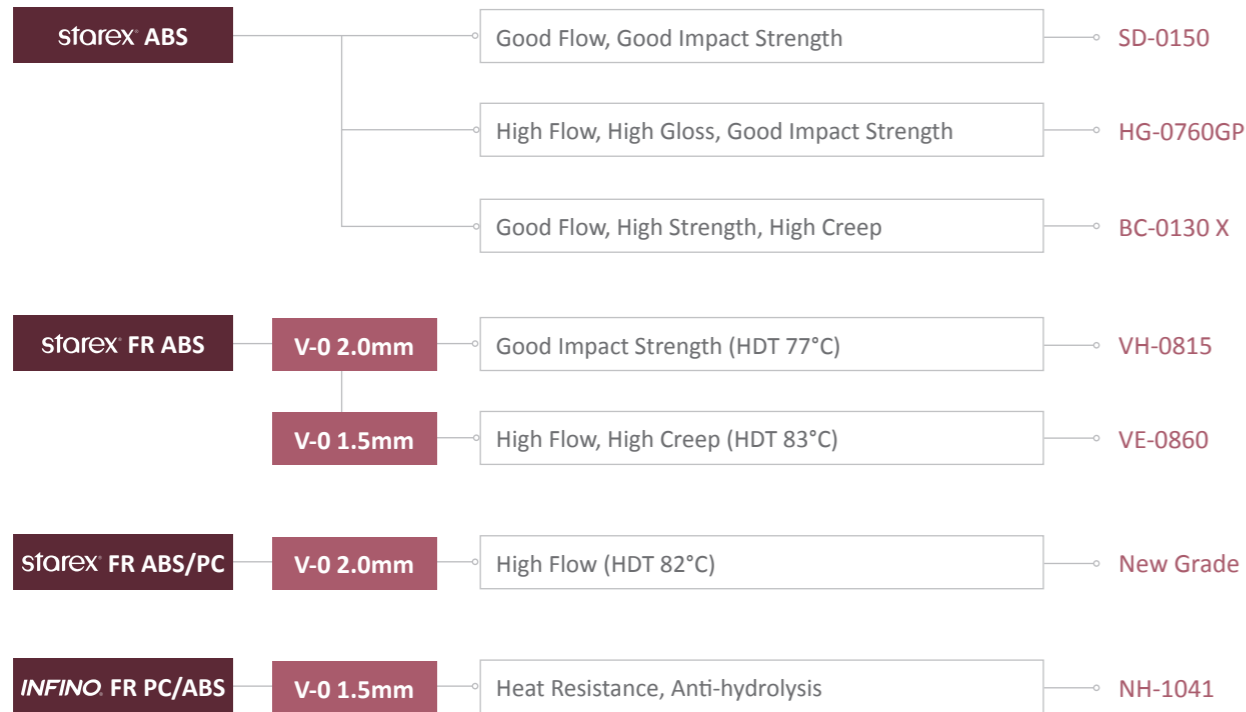

Explore Application & Materials

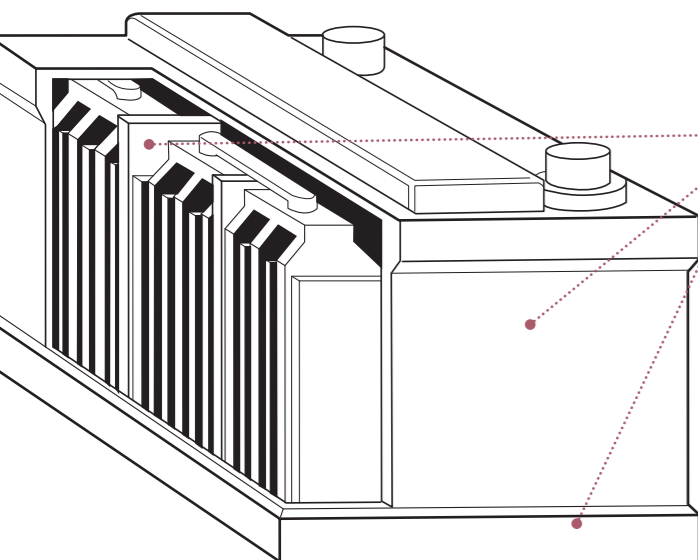

Battery Protective Housing, Cell Divider

High Heat / High Impact

- Flame Retardant ABS
- Flame Retardant & Heat Resistant ABS

High Heat / High Impact / Anti-acid / Anti-hydrolysis

- Flame Retardant PC/ABS

Materials Solutions

>> storex® ABS SD-0150, BC-0130 X

- **Applications** Battery protective housing and cell divider
- **Key Values**

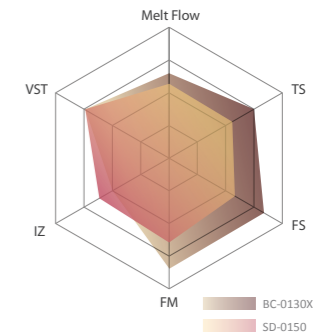
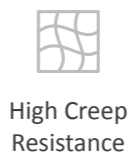
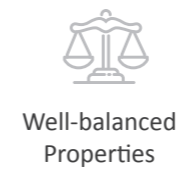

>> storex® FR ABS VH-0815, VE-0860, New FR ABS/PC

- **Applications** Battery protective housing and cell divider
- **Key Values**

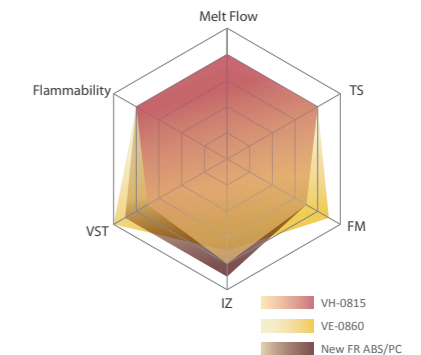

>> INFINO® FR PC/ABS NH-1041

- **Applications** Industrial battery
- **Key Values**

